

3D 切断
Cutting

NEXT
GENERATION
60th 70th

Single Robot Wire Saw シングルロボットワイヤーソー

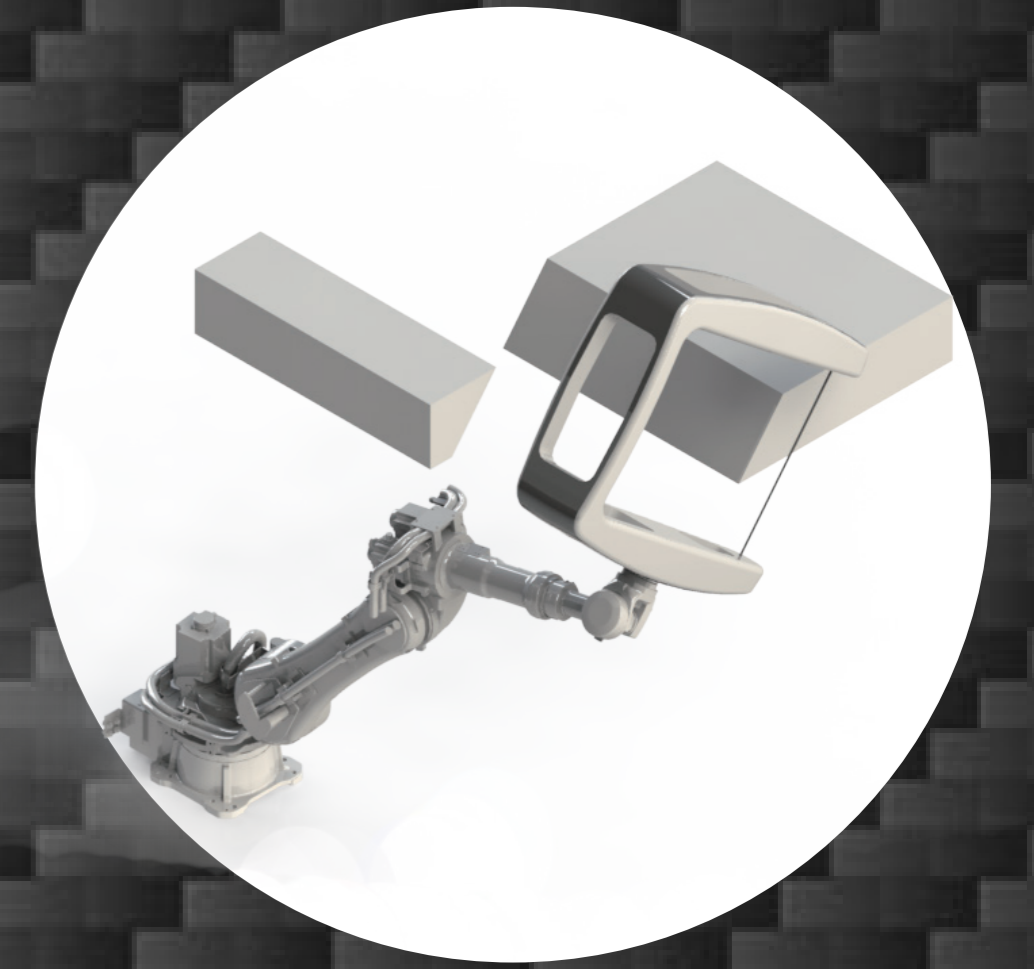
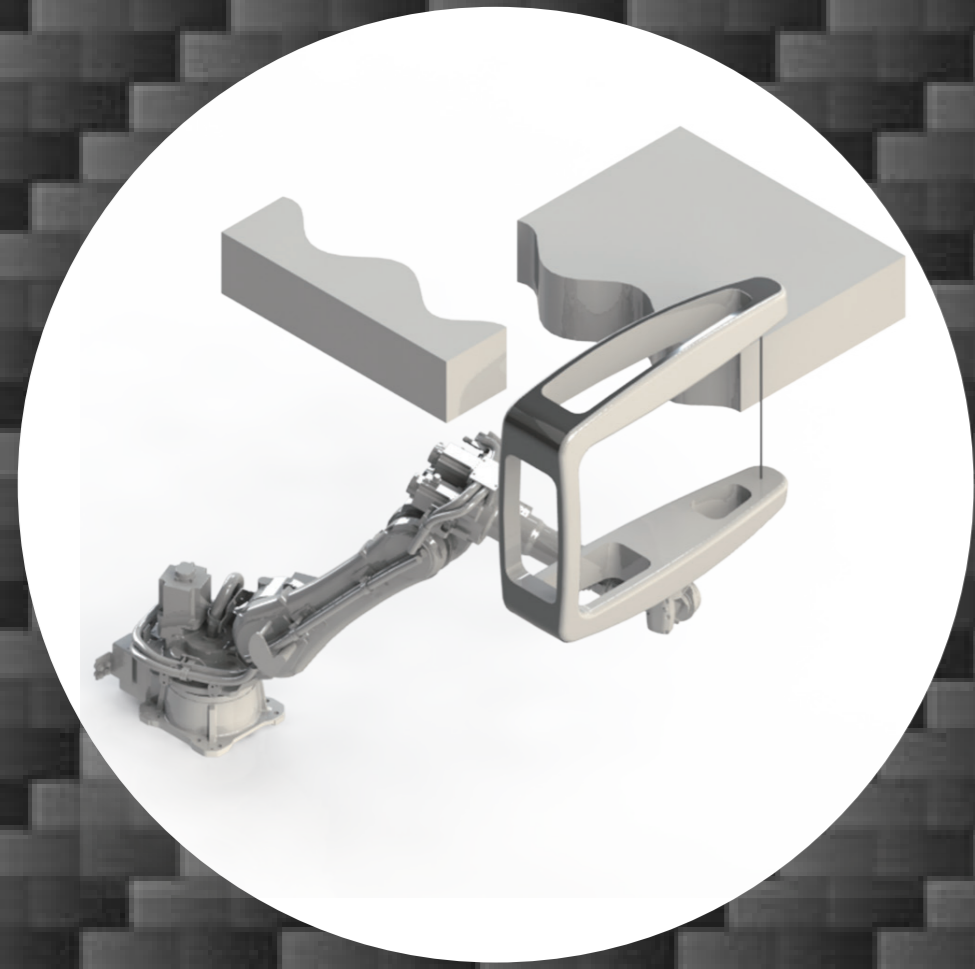

ダイヤモンドワイヤー



- ◆対象ワーク…ハニカム素材、CFRP、CFRP+ハニカム、セラミックス 他
Target material . . . Honeycomb, CFRP, CFRP+Honeycomb, Ceramics others
- ◆切断面精度向上…ダイヤモンドワイヤーによる高精度・高速切断
Improve cutting surface accuracy . . . High-precision and high-speed slicing by diamond wire
- ◆環境対応…ドライ切断による作業環境改善
Environment-responsiveness . . . Improve work environment by dry cutting
- ◆コスト対応…消耗品の削減・低価格加工化によるランニングコスト低減
Cost reduction . . . Reduce running cost by reducing consumables and processing cost.

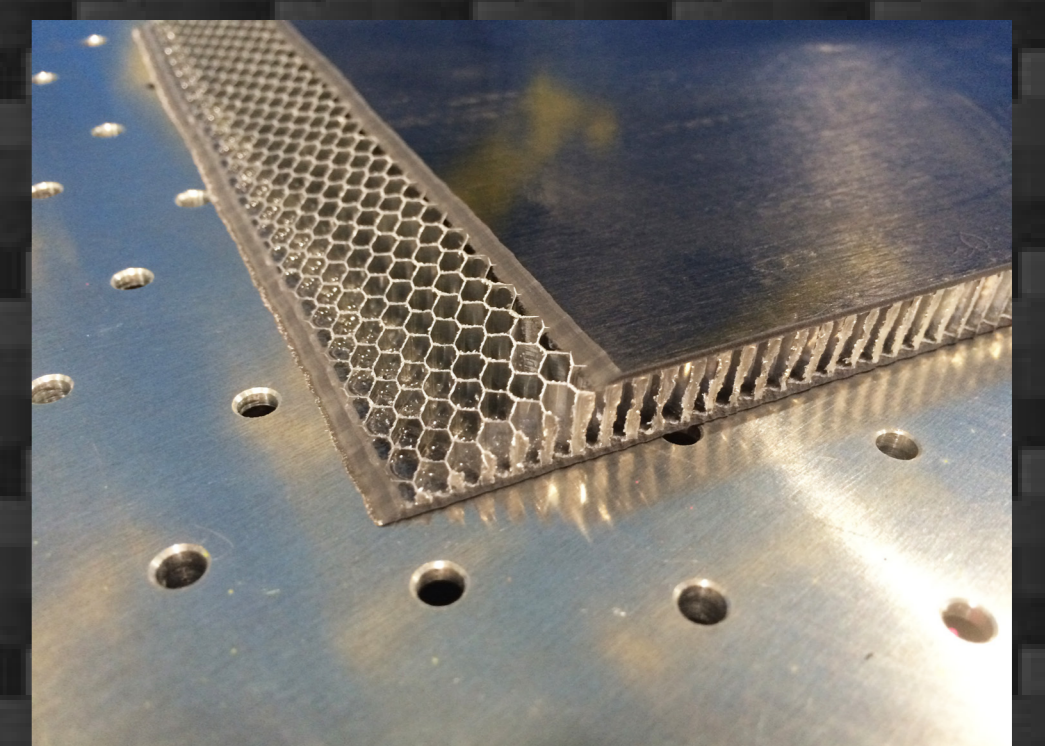
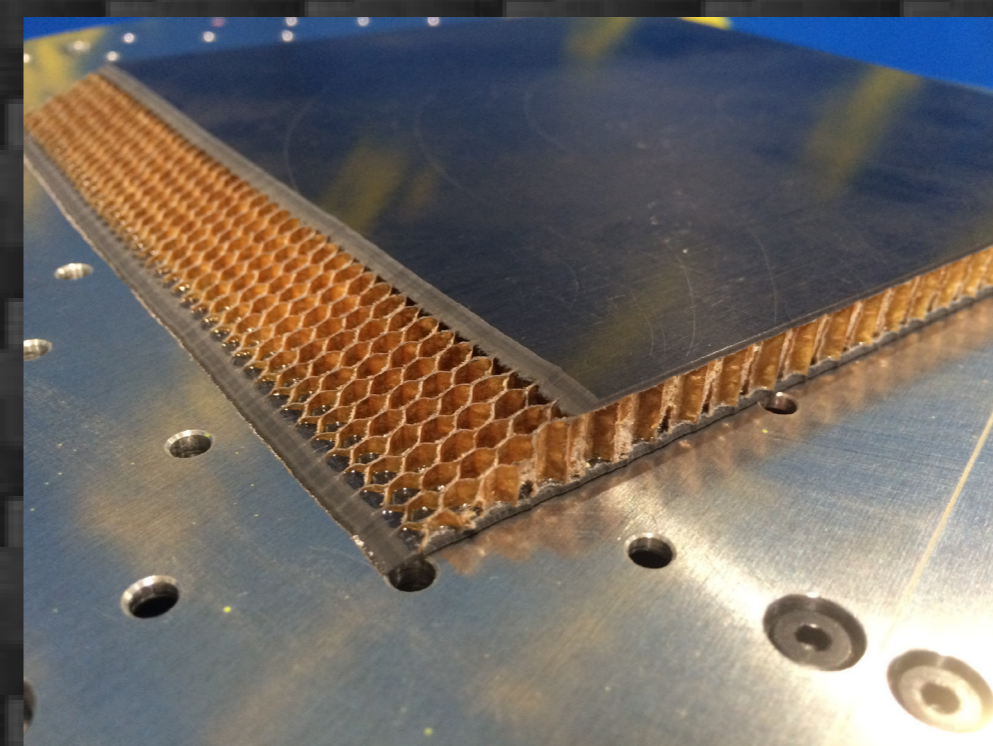
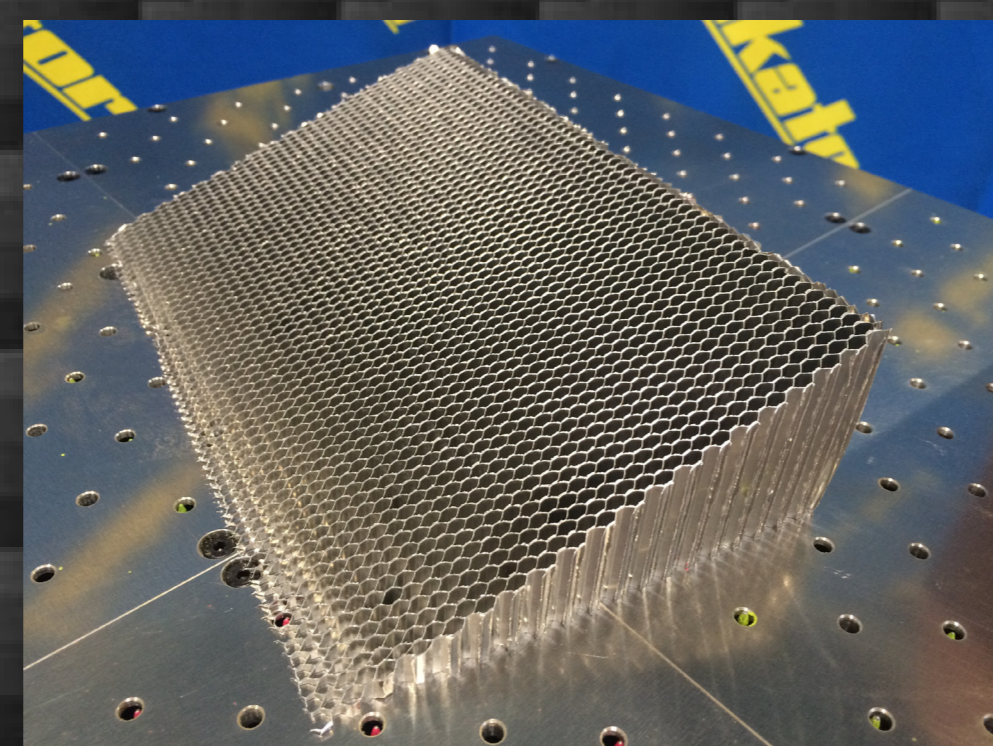
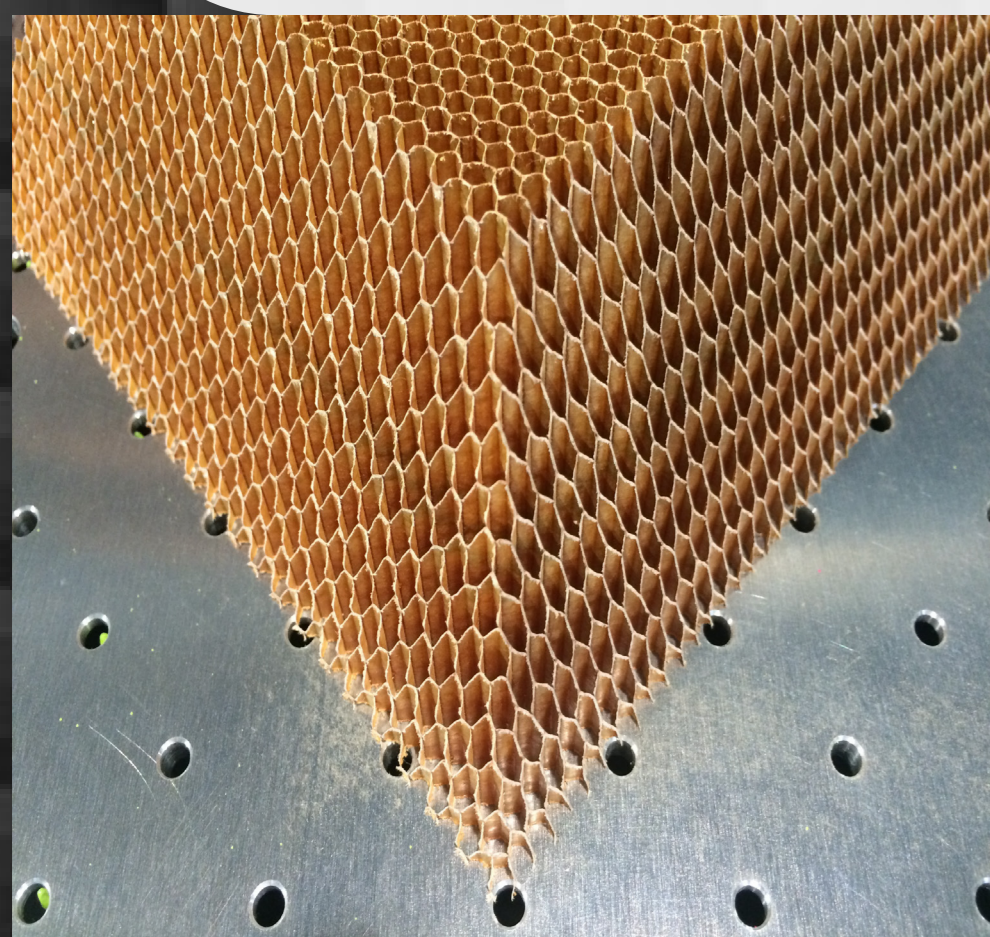

Takatori
The Power of "T"
Technology Trust Teamwork

本 社 / 〒634-8580 奈良県橿原市新堂町 313-1

TEL.0744-24-6608 FAX.0744-24-8352

<http://www.takatori-g.co.jp> E-mail info@takatori-g.co.jp